

Superfine™

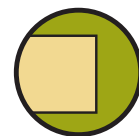

Superfine™

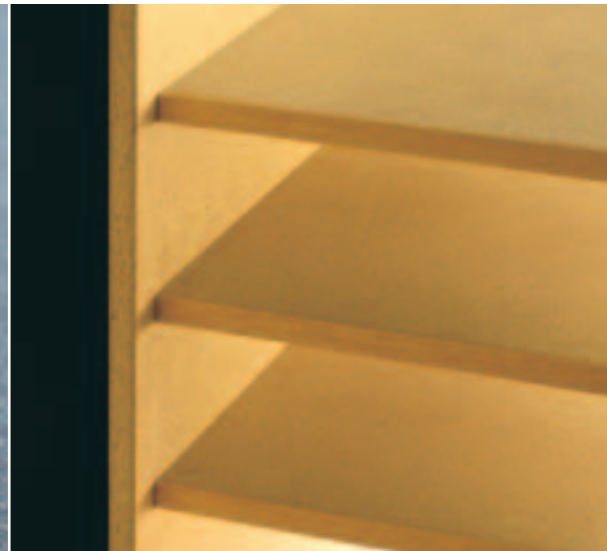
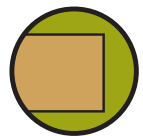

Superfine™
MR

another trade essential from
THE **laminex** GROUP™

Product Description

Superfine and Superfine MR are medium density, grainless, resin bonded particleboard panels which have a fine uniform surface.

Superfine MR (Moisture Resistant) has been developed to provide additional resistance to the effects of moisture in areas subject to high humidity. Superfine MR panels are clearly labelled on the pack banner and are identified by green dye in the core layer of the panel.

Uses:

Superfine

Superfine is specially designed as a substrate for the following applications:

- Vinyl overlays
- Paint finishes
- D.A.P. or low pressure melamine overlays
- Substrate for wood veneer overlays
- Substrate for plastic laminates
- Furniture components
- Commercial shop fittings



Superfine MR

Superfine MR is specially designed as a substrate for the following applications:

- Bathroom vanity units and laundry cupboards
- Bench-top substrates
- Cabinetry in tropical and laboratory locations



Product Details

Durability

When stored, handled, installed and maintained in accordance with this document, Superfine and Superfine MR will meet the provisions of NZBC B2.3.1(c) for five years (dependent on end use).

The Laminex Group will not be liable to any person if the conditions as to storage, handling, installation and maintenance of Superfine or Superfine MR as outlined within this document are not complied with.

Limitations

Superfine and Superfine MR medium density particleboard is interior bonded and is intended for dry interior use only.

Superfine MR medium density particle is a moisture resistant board and must not be used for:

- o Exterior use
- o Clear finishing
- o Areas subject to repeated spillage or extreme dampness
- o Marine uses
- o Exterior door panels

Superfine MR is designed to give improved durability and stability in areas of high humidity but is not waterproof and must not be allowed to come into direct or prolonged contact with water.

Storage

Correct storage procedure will eliminate sagging and permanent distortion of sheets.

- o Store away from heat and direct sunlight.
- o Position 60mm minimum gluts, true to line, on a level dry floor ensuring that they run full pack width.
- o Line gluts vertically one above the other.
- o Place end gluts a maximum 300mm from each end.
- o Provide at least three supports per 2400mm pack and four per 3600mm pack. (Refer Figure 1)

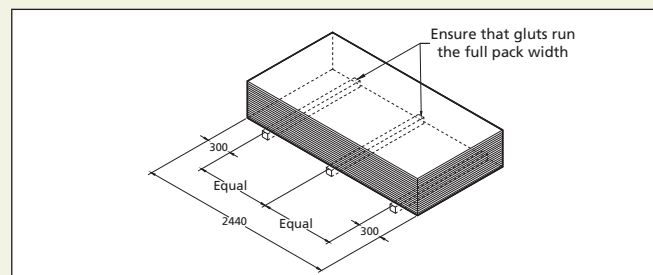

Figure 1

- o Cut strapping as soon as practicable to avoid indentations.
- o Superfine panels must be protected from the weather. A breather type cover must be supported clear of the top and sides of the panels using battens to allow air to circulate freely.

Composition

Superfine and Superfine MR are composed of engineered wood flakes bonded under heat and pressure.

Bonding Adhesives

Superfine: Urea formaldehyde resin

Superfine MR: Melamine urea formaldehyde resin. The resulting particleboard sheets are sanded and ready for use.

Weight Per Unit Area

Thickness (mm)	9	12	15	16	18	25	30
kg/m ²	5.94	7.92	9.90	10.56	11.88	16.00	18.60

Table 1

Tolerances

Dimension	Target	Upper Limit
Length	Nominal	+/- 2mm
Width	Nominal	+/- 2mm
Thickness	Nominal	+/- 0.2mm

Table 2

Squareness - Maximum difference between diagonals:

o 3mm if board length <2000mm

o 4mm if board length 2000mm - 3000mm

o 4.5mm if board length >3000mm

Packaging

o Cover sheets are included at top and bottom of packs to provide edge and surface protection.

o Packs are plastic strapped and should be cut as soon as possible to avoid indenting from moisture uptake.

o Board size and classification are denoted on the pack sides.

Typical Physical Properties for Superfine

Nominal Thickness (mm)						
Physical Property	UNITS	9 mm	12 mm	13 - 19 mm	20 - 29 mm	30 - 33 mm
Moisture Content	%	8	7	7	7	8
Density	Kg/m ³	660	660	660	640	620
Internal Bond	KPa	800	800	750	600	600
Modulus of Rupture	MPa	22	19	17	18	18
Modulus of Elasticity	MPa	2300	2340	2340	2320	2450
Surface Soundness	MPa	-	1.7	2.0	1.7	1.9
Face Screw Holding	N	510	550	690	740	750
Edge Screw Holding	N	-	760	720	610	600
Surface Water Absorption	g/m ²	130	120	110	100	100
Thickness Swell 24hr	%	12	12	9	9	8

Table 3 when tested according to AS/NZS 4266.

Typical Physical Properties for Superfine MR

Nominal Thickness (mm)					
Physical Property	UNITS	12 mm	13 - 19 mm	20 - 29 mm	30 - 33 mm
Moisture Content	%	7	7.5	8	8.5
Density	Kg/m ³	660	660	640	620
Internal Bond	KPa	950	950	900	900
Modulus of Rupture	MPa	23	21	19	18
Modulus of Elasticity	MPa	2710	2540	2500	2460
Surface Soundness	MPa	1.7	2.0	2.0	2.1
Face Screw Holding	N	620	650	750	840
Edge Screw Holding	N	830	850	800	770
Surface Water Absorption	g/m ²	110	100	90	90
Thickness Swell 24hr	%	6	5	4	2.5

Table 4 when tested according to AS/NZS 4266.

Shelf Load Span Table (kg/m²)

Span Type	Thickness (mm)	Span (m)									
		0.3	0.4	0.5	0.6	0.7	0.8	0.9	1.0	1.1	1.2
Single Span	9	106	45	23	13	8	6	4	3	2	2
	12	251	106	54	31	20	13	9	7	5	4
	16	594	251	128	74	47	31	22	16	12	9
Multiple Span	18	846	357	183	106	67	45	31	23	17	13
	9	199	84	43	25	16	11	7	5	4	3
	12	473	199	102	59	37	25	18	13	10	7
	16	1121	473	242	140	88	59	42	30	23	18
	18	1595	673	345	199	126	84	59	43	32	25

Table 5

NOTE:

1. Spans based on a creep factor of 2.0 with a limiting deflection of 0.006 x span.
2. Loadings uniformly distributed.

Fungal and Insect Resistance

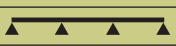
Superfine will resist fungal decay and household borer infestation provided the moisture content does not exceed 18% for prolonged periods.

Hygroexpansivity (Sheet Expansion)

Attention to correct storage, preconditioning and stock rotation will minimise the effects of dimensional fluctuations and edge peaking resulting from changes in relative humidity.

Effects of Heat

Precautions must be taken to ensure that Superfine is kept clear of nearby sources of heat, such as free standing fire places, space heaters, wall ovens, hot plates etc. The structural life of Superfine may be impaired if surface temperatures exceed 50°C.

Manufacturers of heat appliances, must be consulted to ascertain the clearances or protection required to ensure 50°C is not exceeded.

Design Considerations

Surface and Edge Finishing

- o Staining and clear coating are not recommended for Superfine.
- o Wood veneer and melamine edge banding, PVC and ABS edging, solid timber clashing and paste type edge fillers may all be used on Superfine particleboards.

Handling and Product Care

- o As with most woodbased products, Superfine will increase in dimension in proportion to any increase in the board moisture content and to the relative humidity of the situation in which they are placed.
- o Adequate preconditioning and precise following of installation instructions are essential for satisfactory results, especially during wet seasons and high humidity.

Stock Rotation

The uptake of atmospheric moisture into board edges will be minimised by regular stock turn around. Cut strapping immediately to avoid indentations. Avoid storing close to doorways adjacent to external atmosphere.

Preparation

Lamination of balancing veneers is recommended in single sided uses.

Optimum results are gained when boards are preconditioned to balance internal moisture content before processing. Minor cupping or bowing, possibly initiated by the laminating processes, can be accentuated by rapid humidity changes. Under normal conditions boards will recover relatively quickly.

A balancing veneer or surfacing system is recommended as single or unbalanced laminations can cause warping.

Adhesives

Superfine panels can be readily jointed or bonded with standard woodworking adhesives, such as Rakoll GXL3. High volume manufacture may require alternative methods such as gun applied hot melt systems.

Dowel Jointing

Superfine panels can be successfully butt jointed edge to face. The joint must be given added strength with a widely used method of glue and dowels.

Assembly Fittings

Owing to gathering emphasis placed on “knock down” systems, manufacturers have developed efficient hinges and fittings to assist ease of assembly.

Some of these are as follows :

o Concealed Hinge

Cup hinges are inserted into a pre-drilled hole in the door and screw fixed. The mounting plate is fastened to the carcass. The hinge arm slides on to the baseplate and is secured by a screw on the hinge arm. The hinge is adjustable in three directions allowing for perfect door alignment. A built in catch in the hinge arm keeps the door closed. (Refer Figure 2)

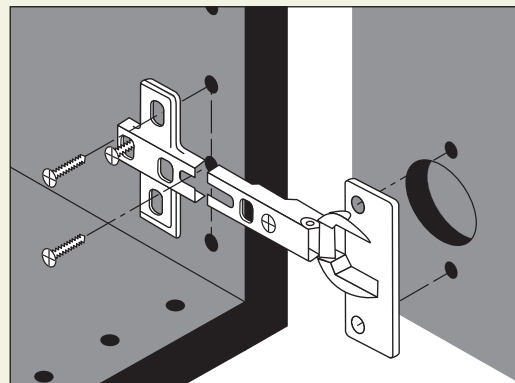

Figure 2

o Confirmat screws

These screws are used for right angled joints. 50mm or 70mm long screws are fitted into a pilot hole using a special drill bit. A plastic cover cap fits into the head to conceal the screw. (Refer Figure 3)

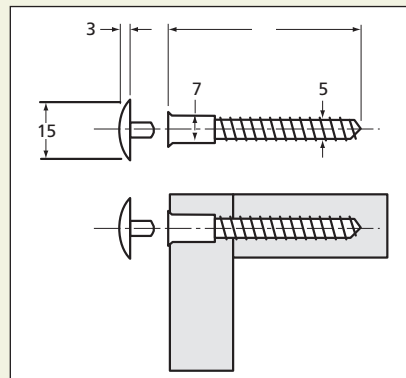

Figure 3

o **Drawer Slides**

Slides are mainly epoxy coated steel with nylon rollers or ball bearing races. These are easily fitted and give superb smooth gliding action. (Refer Figure 4)

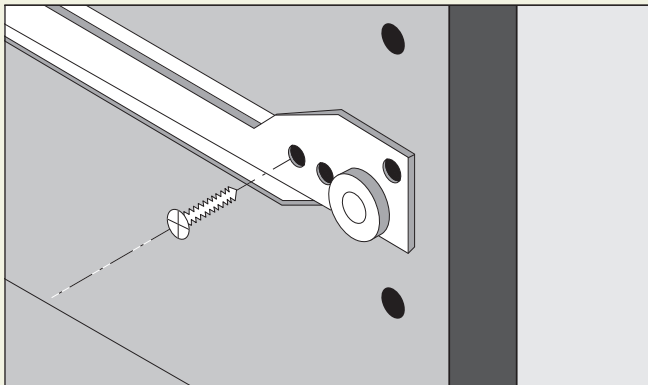

Figure 4

o **Cam Connector System**

This is designed to give strong unobtrusive joining of boards of a minimum of 15mm thickness at right angles. The steel connector bolt is screwed into the face of one board. It then passes through a predrilled hole in the edge of the other board, locating at 15mm diameter zinc cam. The cam is then twisted with a screwdriver to apply joining pressure. A cover cap can then be placed over the cam, which can be removed if the units are to be separated. (Refer Figure 5)

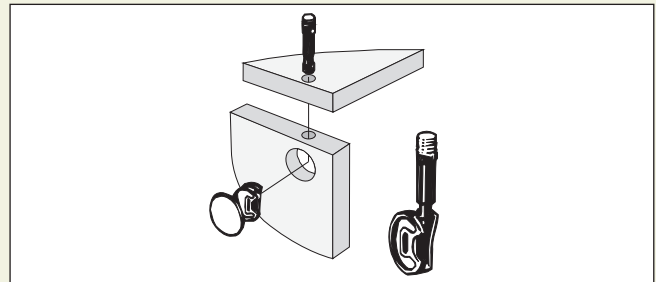

Figure 5

V-Grooving and Mitre Folding

Machining and assembly of Superfine cabinet components using decorative vinyl film as the fulcrum of hinge at corners gives greater design flexibility and joint accuracy. It eliminates the matching of individual component parts.

Decorative plastic laminates and wood veneers may be used when a purpose made plastic tape is adhered to the face of the overlay forming the hinge when folding prior to gluing. Grooving cuts are taken through the substrate to the back of the tape. Superior groove profiles are achieved using saws rather than cutter systems.

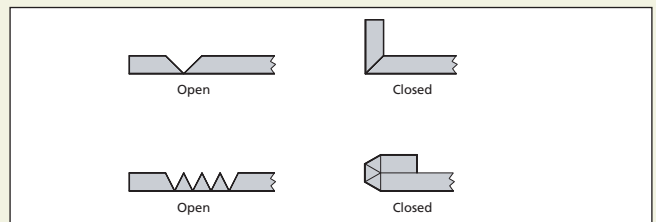

Figure 6

Working Characteristics

Workability

Superfine is easily cut with a fine toothed hand saw or circular saw adjusted to protrude just through the board surface. Tungsten-tipped machine tools are recommended for volume production.

Machining and Drilling

Superfine can be easily machined, grooved and routed in any direction. To avoid offside break-out apply only nominal pressure when using power drills.

NOTE:

Always use approved eye protection when machining particle board. For best results ensure hand and machine tools are sharp.

Screw Fixing

Twinfast self centering screws or particleboard screws, available with single and cross slotted heads, are suitable for fixing into the edge and face of Superfine. Full length parallel twin threads provide up to 25% more holding power and penetrate faster into the particle board than conventional wood screws. Plated screws are advisable, to avoid corrosion stains discolouring board surface.

Pilot Hole Sizes

Screw Gauge	3	4	5	6	7	8	9	10
Pilot Hole Size (mm)	1.00	1.25	1.45	1.60	1.65	1.95	2.10	2.25

Table 6

Laminated Panels

Cutting

Particular care must be taken with sheets overlaid with printed papers, vinyls, DAP or melamine laminates. Place face side of sheet uppermost when using conventional bench saw and downwards if using a portable electric saw. See also "Machining and Drilling".

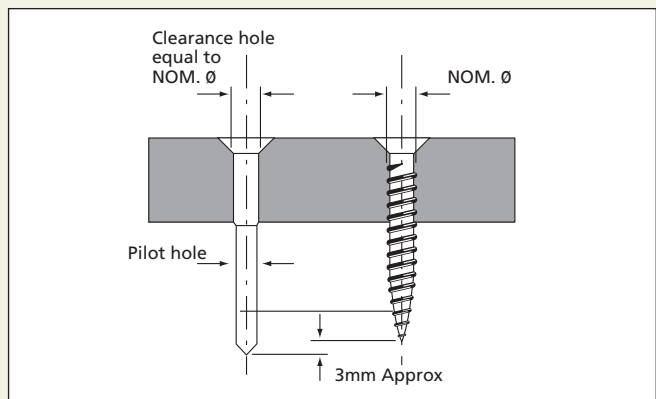

Figure 7

Liability

The Laminex Group will not be liable to any person if the instructions as to storage, use and installation of Lakepine as outlined in this brochure are not complied with.

Any proprietary products referred to in this brochure must be used in accordance with the relevant manufacturer's instructions. The Laminex Group accepts no liability for these proprietary products.

Nothing contained in this paragraph or elsewhere in this brochure affects any rights a person may have under the Consumer Guarantees Act 1993.

This brochure supersedes all previous issues.

All Acts, Codes and Standards referred to in this brochure are the current editions at the date of brochure publication.



Health and Safety

Health and safety precautions must be taken when working with wood products.

- o Exposure to wood dust and/or to formaldehyde may cause irritation to the eyes, respiratory system and skin, and may cause sensitisation resulting in asthma, and by skin contact resulting in dermatitis.
- o Wood dust is classified as a known carcinogen. Repeated inhalation of wood dust over many years may cause nasal cancer.
- o Formaldehyde is classified as a known carcinogen.
- o Storage areas containing large quantities of Superfine must be adequately ventilated.
- o Work areas must be well ventilated and kept clean. Sawing, sanding and machining equipment must be fitted with dust extractors to ensure that dust levels are kept within standards laid down by Worksafe Australia, Occupational Health and Safety New Zealand, or the specific country of use. If not, a dust mask conforming with AS/NZS 1715 and AS/NZS 1716 and eye protection conforming with AS/NZS 1337 must be worn.
- o Offcuts, shavings and dust must be disposed of in a manner which avoids the generation of dust and in accordance with the requirements of local waste authorities.
- o In end use applications all product surfaces exposed to occupied space must be sealed.

For further information and safety data information, please phone The Laminex Group Customer Services Department.

0800 303 606

www.thelaminexgroup.co.nz

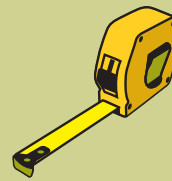

Technical Support

As not all product use options can be described in this brochure, additional end use and specifying information is available as a complimentary service. The information contained in this brochure must not be reproduced or published in whole or in part without the prior consent of The Laminex Group. The Laminex Group reserves the right to revise without notice any information contained in this brochure. Please contact The Laminex Group Customer Services Department to check the currency of information contained in this brochure, or visit the website:

www.thelaminexgroup.co.nz

Address Details:

The Laminex Group

24-26 O'Rorke Road,
Penrose, Auckland,
New Zealand

PO Box 12 270,
Penrose

Customer Services

Ph 0800 303 606

Fax 0800 303 707

Copyright Reserved. June 2005. The Laminex Group, Auckland, New Zealand
Manufactured by The Laminex Group. A division of FLETCHER BUILDING PRODUCTS LTD